

Features

- 4:1 Wide input 4.5~75V DC
- Isolation Voltage: 1600V DC & 3000V - DC Depending on model
- Operating Temperature Range: -40~71°C
- Approved to cURus, UKCA, CE, RoHS, REACH
- Safety standards to IEC/EN/UL 62368-1
- Efficiency up to 83%
- EMC Class A & B Certified

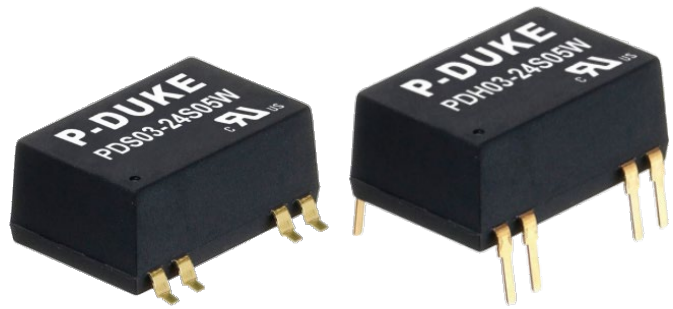

Ideal Power's 43PDH03-xyzW 3W Series SMD, DIP DC/DC Converters are certified to cURus, UKCA, CE, RoHS, REACH & IEC/UL/EN 62368-1 Standards and comply with the relevant Efficiency Regulations. These are primarily used in ITE, Video & Audio Industries and customised solutions are available upon request.

Part Number Structure

PDS03	-	48	S	05	W	H
Series Name		Output Power (VDC)	Output Quantity	Output Voltage (VDC)	Input Range	Isolation Voltage (VDC)
PDS: SMD type		12: 4.5~18	S: Single	3P3: 3.3	4 : 1	□: Standard type
PDH: DIP type		24: 9~36		05: 5		1600VDC isolation
		48: 36~75		09: 9		H: 3000VDC isolation
			D: Dual	12: 12		
				15: 15		
				05: ±5		
				12: ±12		
				15: ±15		

Models

Model Number	Input Range VDC	Output Voltage VDC	Output current @ Full Load mA	Input Current @ No Load A	Efficiency %	Maximum Capacitor Load µF
43PDS(H)03-12S3P3W	4.5~18	3.3	700	35	75	3300
43PDS(H)03-12S05W	4.5~18	5	600	35	81	1680
43PDS(H)03-12S09W	4.5~18	9	333	35	80	1000
43PDS(H)03-12S12W	4.5~18	12	250	35	82	820
43PDS(H)03-12S15W	4.5~18	15	200	35	82	680
43PDS(H)03-12D05W	4.5~18	±5	±300	40	79	±1000
43PDS(H)03-12D12W	4.5~18	±12	±125	40	82	±470
43PDS(H)03-12D15W	4.5~18	±15	±100	20	81	±330
43PDS(H)03-24S3P3W	9~36	3.3	700	20	75	3300
43PDS(H)03-24S05W	9~36	5	600	20	80	1680
43PDS(H)03-24S09W	9~36	9	333	20	80	1000
43PDS(H)03-24S12W	9~36	12	250	20	82	820
43PDS(H)03-24S15W	9~36	15	200	20	82	680
43PDS(H)03-24D05W	9~36	±5	±300	20	79	±1000
43PDS(H)03-24D12W	9~36	±12	±125	20	82	±470
43PDS(H)03-24D15W	9~36	±15	±100	13	81	±330
43PDS(H)03-48S3P3W	18~75	3.3	700	13	75	3300
43PDS(H)03-48S05W	18~75	5	600	13	80	1680
43PDS(H)03-48S09W	18~75	9	333	13	80	1000
43PDS(H)03-48S12W	18~75	12	250	13	83	820
43PDS(H)03-48S15W	18~75	15	200	13	82	680
43PDS(H)03-48D05W	18~75	±5	±300	13	79	±1000
43PDS(H)03-48D12W	18~75	±12	±125	13	82	±470
43PDS(H)03-48D15W	18~75	±15	±100	13	81	±330

Input Specifications

Parameter	Conditions	Min	Typ	Max	Unit
Operating input voltage range	12Vin(nom)	4.5	12	18	VDC
	24Vin(nom)	9	24	36	
	48Vin(nom)	18	48	75	
Start-up time	Constant resistive load	Power up	5		ms
		Remote ON/OFF	5		
Input surge voltage	1 Second, max.	12Vin(nom)		25	VDC
		24Vin(nom)		50	
		48Vin(nom)		100	
Input filter				Capacitor Type	
	Ctrl pin applied current via 1kΩ				
		DC_DC ON		Open or high impedance	
		DC_DC OFF			
		Remote off input current	2	3	4
					2.5
					mA
					mA

Application circuit
DC-DC ON

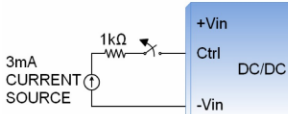

DC-DC OFF

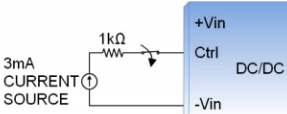

Output Specifications

Parameter	Conditions		Min	Typ	Max	Unit
Voltage accuracy			-1.0		+1.0	Watts
Line regulation	Low Line to High Line at Full Load		-0.2		+0.2	%
Load regulation	No Load to Full Load	Single	-1.0		+1.0	%
		Dual	-1.0		+1.0	
	10% Load to 100% Full Load	Single	-0.5		+0.5	
		Dual	-0.8		+0.8	
Cross regulation	Asymmetrical load 25%/100% FL	Dual	-5.0		+5.0	
Ripple and Noise	20MHz bandwidth			30		mVp-p
Temperature coefficient			-0.02		+0.02	%/°C
Transient response recovery time	25% Load step change			250		µs
Short circuit protection			Continuous, automatic recovery			

General Specifications

Parameter	Conditions		Min	Typ	Max	Unit
Isolation voltage	1 minute	Input to Output	1600			V DC
		Standard Suffix "H"	3000			
Isolation resistance	500VDC		1			GΩ
Isolation capacitance		Standard Suffix "H"			50	
					50	
Switching frequency	Full load to minimum load		100			kHz
Safety approvals	IEC/ EN/ UL62368-1					UL:E193009 CB:UL(Demko)
Weight						4.5g (0.16oz)
MTBF	MIL-HDBK-217F, Full load					5.738 x 10 ⁶ hrs

Environmental Specifications

Parameter	Conditions		Min	Typ	Max	Unit
Operating ambient temperature	Without derating		-40		+71	°C
	With derating		+85		+100	
Maximin case temperature					100	
Storage temperature range			-55		+125	°C
Thermal Shock						MIL-STD-810F
Vibration						MIL-STD-810F
Relative humidity						5% to 95% RH
Lead-free reflow solder process	Only for SMD type					IPC J-STD-020E
Moisture sensitivity level(MSL)	Only for SMD type					IPC J-STD-033C Level 2a

EMC Specifications

Parameter	Conditions	Level
EMI	EN55022 With external components	Class A, Class B
EMS	EN55024	
ESD	EN61000-4-2 Air ± 8 kV and Contact ± 6 kV	Perf. Criteria A
Radiated immunity	EN61000-4-3 10 V/m	Perf. Criteria A
Fast transient	EN61000-4-4 ± 2 kV With an external input filter capacitor (Nippon chemi-con KY series, 220 μ F/100V)	Perf. Criteria A
Surge	EN61000-4-5 ± 1 kV With an external input filter capacitor (Nippon chemi-con KY series, 220 μ F/100V)	Perf. Criteria A
Conducted immunity	EN61000-4-6 10 Vr.m.s	Perf. Criteria A
Power frequency magnetic field	EN61000-4-8 100A/m continuous; 1000A/m 1 second	Perf. Criteria A

CAUTION: This power module is not internally fused. An input line fuse must always be used.

Characteristic Curve

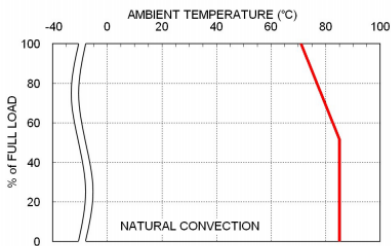

43PDS03-48S05W Derating Curve

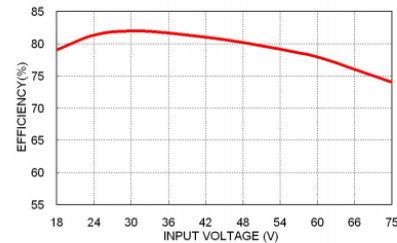

43PDS03-48S05W Efficiency vs. Input Voltage

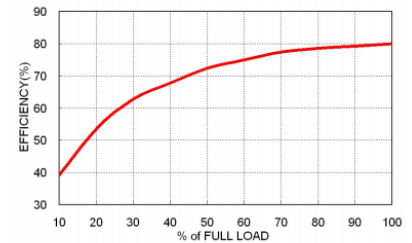

43PDS03-48S05W Efficiency vs. Output Load

Fuse Considerations

This power module is not internally fused. An input line fuse must always be used. This encapsulated power module can be used in a wide variety of applications, ranging from simple stand-alone operation to an integrated part of sophisticated power architecture. To maximum flexibility, internal fusing is not included; however, to achieve maximum safety and system protection, always use an input line fuse. The input line fuse suggest as below :

Model	Fuse Rating (A)	Fuse Type
43PDS(H)03-12S□□W, 43PDS(H)03-12D□□W	2.5	Slow-Blow
43PDS(H)03-24S□□W, 43PDS(H)03-24D□□W	1.5	Slow-Blow
43PDS(H)03-48S□□W, 43PDS(H)03-48D□□W	1	Slow-Blow

The table based on the information provided in this data sheet on inrush energy and maximum DC input current at low Vin.

Mechanical Drawing

43PDS03W

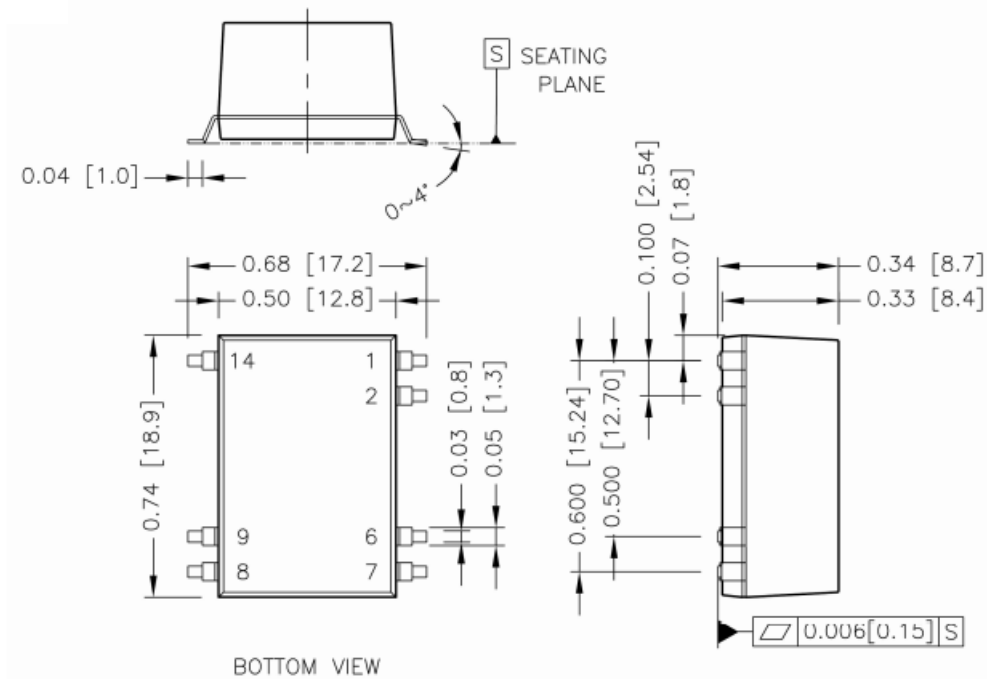

1. All dimensions in inch (mm)
2. Tolerance :x.xx±0.02 (x.x±0.5)
x.xxx±0.01 (x.xx±0.25)
3. Pin pitch tolerance ±0.01 (0.25)
4. Pin dimension tolerance ±0.004(0.1)

DIP Pin Connection

Pin	Single	Dual
1	-Vin	-Vin
2	Ctrl	Ctrl
6	NC	Common
7	NC	_Vout
8	+Vout	+Vout
9	-Vout	Common
14	+Vin	+Vin

Mechanical Drawing (Continued)

43PDH03

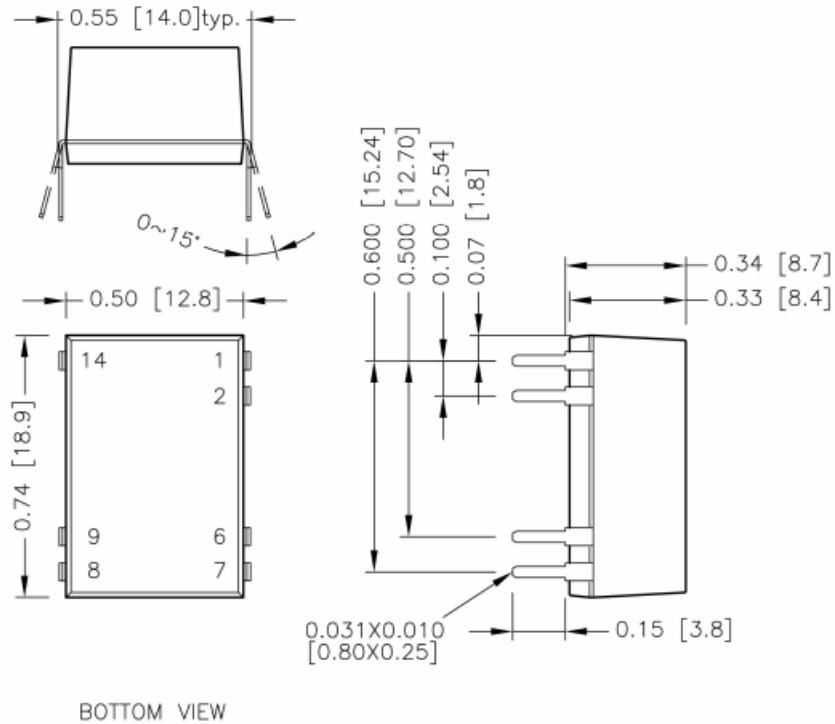

BOTTOM VIEW

1. All dimensions in inch (mm)
2. Tolerance :x.xx±0.02 (x.x±0.5)
x.xxx±0.01 (x.xx±0.25)
3. Pin pitch tolerance ±0.01 (0.25)
4. Pin dimension tolerance ±0.004(0.1)

DIP Pin Connection

Pin	Single	Dual
1	-Vin	-Vin
2	Ctrl	Ctrl
6	NC	Common
7	NC	_Vout
8	+Vout	+Vout
9	-Vout	Common
14	+Vin	+Vin

Recommended Pad Layout

43PDS02W

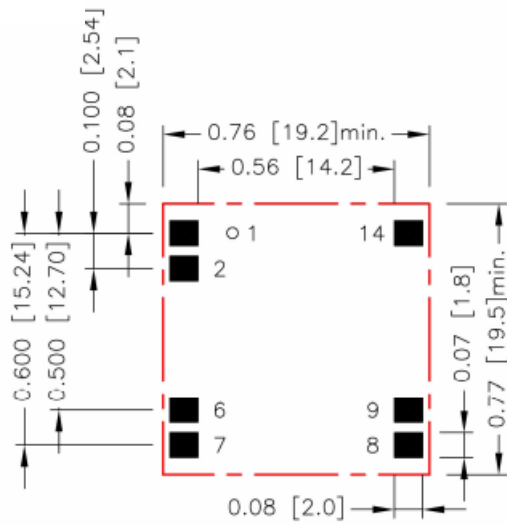

All dimensions in inch[mm]
 Pad size(lead free recommended)
 Top view pad:0.080x0.070[2.00x1.80]

43PDH02W

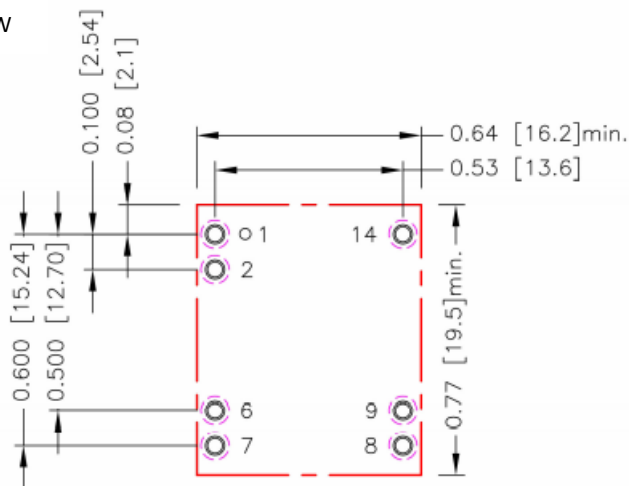

All dimensions in inch[mm]
 Pad size(lead free recommended)
 Through hole 1.2.6.7.8.9.14: Φ 0.043[1.10]
 Top view pad 1.2.6.7.8.9.14: Φ 0.055[1.40]
 Bottom view pad 1.2.6.7.8.9.14: Φ 0.080[2.04]

Thermal Considerations

The power module operates in a variety of thermal environments. However, sufficient cooling should be provided to help ensure reliable operation of the unit. Heat is removed by conduction, convection, and radiation to the surrounding Environment. Proper cooling can be verified by measuring the point as the figure below. The temperature at this location should not exceed "Maximum case temperature". When Operating, adequate cooling must be provided to maintain the test point temperature at or below "Maximum case temperature". You can limit this Temperature to a lower value for extremely high reliability.

v Thermal test condition with vertical direction by natural convection (20LFM).

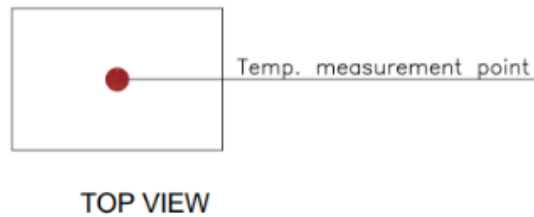

Lead Free Reflow Profile (For SMD Type)

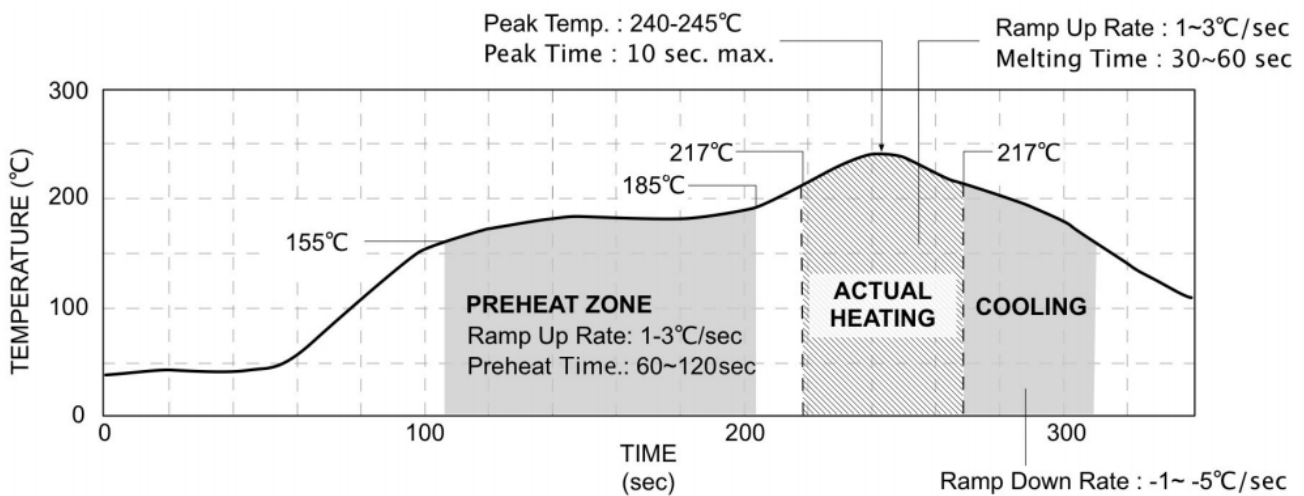

*The curves define the maximum peak reflow temperature permissible measured on pin1 or Vin pin.